

# MMIC Surface Mount Wideband Double Balanced Mixer

## MDB-24H+

Level 15 (LO Power 15dBm) 5-21.5 GHz

### The Big Deal

- High L-I Isolation, 44 dB typ
- Useable as Up & Down Converter
- Small Size 4 x 4 x 1 mm



CASE STYLE: DG1847

### Product Overview

MDB-24H+ is an advanced wideband frequency mixer fabricated using InGaP HBT technology with integrated LO and RF Baluns. It has repeatable performance making it suitable for volume production. It is packaged in tiny 4 mm x 4 mm x 1 mm MCLP™ Package having Tin Silver Nickel finish passing tin whisker test.

### Key Features

Feature	Advantages
Double Balanced	Results in excellent LO-RF (21-35 dB typical) & LO-IF (28-44 dB typical) Isolations minimizing need for external filtering
Wide Bandwidth, 5 to 21.5 GHz	Useful in wideband systems or in in several narrowband systems. Reducing inventory
Wide IF Bandwidth DC-5 GHz	Usable in first and second down converter applications. IF as low as DC enables use in phase detector applications.
4 mm x 4 mm, 24 lead MCLP Package	Low Inductance, repeatable transitions, excellent thermal contact to PCB

# MMIC Surface Mount Wideband Double Balanced Mixer

## MDB-24H+

Level 15 (LO Power 15dBm) 5-21.5 GHz

### Product Features

- Wide bandwidth 5 to 21.5 GHz
- High L-I Isolation, 44 dB typ. at 15 GHz
- Useable as Up & Down Converter
- Small Size 4 mm x 4 mm x 1 mm
- Aqueous washable
- Footprint Compatible with Hittite HMC144LC4<sup>a,b</sup>



CASE STYLE: DG1847

### +RoHS Compliant

The +Suffix identifies RoHS Compliance. See our web site for RoHS Compliance methodologies and qualifications

### Typical Applications

- Satellite up and down converters
- Defense radar & communication
- VSAT
- Line of sight links
- Federal fixed service
- WiFi
- ISM

### General Description

MDB-24H+ is an advanced wideband frequency mixer fabricated using InGaP HBT technology with integrated LO and RF Baluns. It has repeatable performance making it suitable for volume production. It is packaged in tiny 4 mm x 4 mm x 1 mm MCLP™ Package having Tin Silver Nickel finish passing tin whisker test.

### simplified schematic and bonding pad description

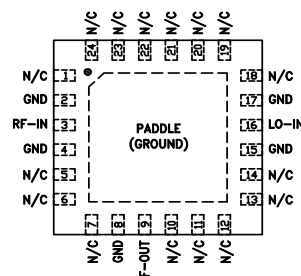
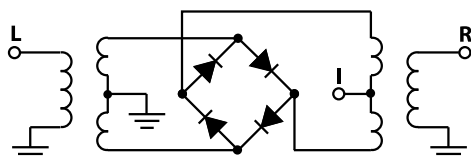

Function	Pad Number	Description
RF-IN	3	RF input
LO-IN	16	LO input
IF-OUT	9	IF input
GND	2,4,8,15,17, Paddle	Connect to Ground
NC	1, 5-7, 10-14, 18-24	No connection, not used

#### Notes:

- Suitability for model replacement within a particular system must be determined by and is solely the responsibility of the customer based on, among other things, electrical performance criteria, stimulus conditions, application, compatibility with other components and environmental conditions and stresses.
- The Hittite HMC144LC4 part number is used for identification and comparison purposes only.

**Electrical Specifications<sup>1</sup> at 25°C, unless noted**

Parameter	Condition (GHz)	Min.	Typ.	Max.	Units
RF Frequency Range		5		21.5	GHz
LO Frequency Range		5		21.5	GHz
IF Frequency Range		DC		5	GHz
LO Power			+15		dBm
Conversion Loss (at IF=30 MHz)	5	—	6.9	—	dB
	10	—	9.0	—	
	15	—	7.9	8.9	
	20	—	9.4	—	
	21.5	—	10.3	11.7	
LO-RF Isolation	5	—	28	—	
	10	—	33	—	
	15	29	35	—	
	20	—	21	—	
	21.5	—	25	—	
LO-IF Isolation	5	—	28	—	dB
	10	—	36	—	
	15	35	44	—	
	20	—	36	—	
	21.5	—	39	—	
RF-IF Isolation	5		10		dB
	10		15		
	15		22		
	20		22		
	21.5		21		
Input at 1dB Compression	5-21.5		10		dBm
Input IP3	5		14		dBm
	10		21		
	15		23		
	20		24		
	21.5		23		
Noise Figure	5		6.9		dB
Thermal Resistance (junction-to-ground lead)			105		°C/W

<sup>(1)</sup> Measured on Mini-Circuits Characterization test board TB-851+. See Characterization Test Circuit Figure 1

**Absolute Maximum Ratings<sup>2</sup>**

Parameter	Ratings
Operating Temperature	-40°C to 85°C
Storage Temperature	-65°C to 150°C
RF Power	21 dBm
LO Power	21 dBm
IF Current	30 mA

<sup>2</sup> Permanent damage may occur if any of these limits are exceeded.  
Electrical maximum ratings are not intended for continuous normal operation.

**Characterization Test Circuit**

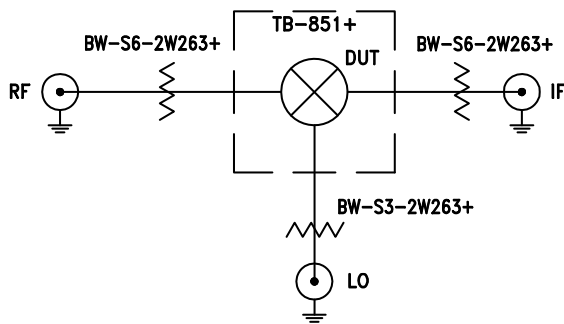

Figure 1A.  
Block Diagram of Test Circuit used for characterization of Conversion Loss, Isolations (LO-RF, LO-IF, RF-IF) and Return Loss (LO, RF, IF)

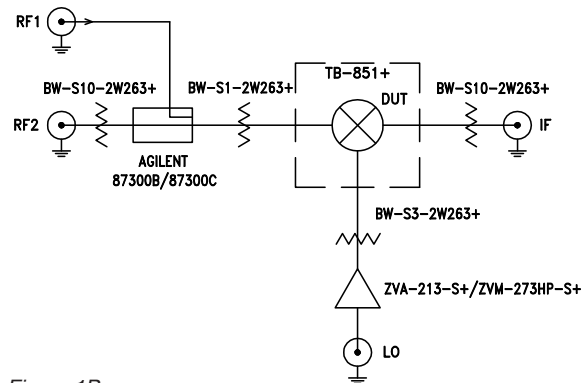

Figure 1B.  
Block Diagram of Test Circuit used for characterization of Input IP3

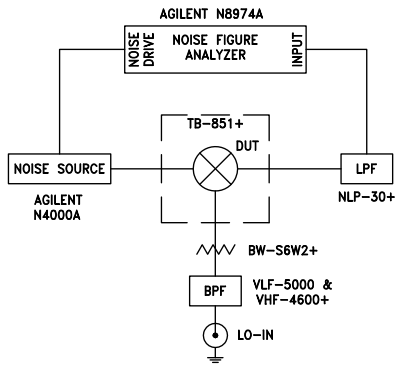

Figure 1C.  
Block Diagram of Test Circuit used for characterization of Noise Figure

Figure 1. Block Diagram of Test Circuit used for characterization. (DUT soldered on Mini-Circuits Characterization test board TB-851+). Conversion Loss, Isolations; L-R, L-I & R-I are measured using R&S ZVA 24 microwave network analyzer. Input IP3 is measured Agilent MXA N9020A spectrum Analyzer and PSG E8257D Signal Generators. NF is measured using Agilent's N8974A NF Analyzer

Conditions (Down Converter):

1. Conversion Loss, Isolations (L-R, L-I & R-I): RF= 0 dBm, LO=+15 dBm, IF=30 MHz
2. Output IP3 (OIP3): Two tones, spaced 1 MHz apart, 0 dBm/tone at output.
3. Noise Figure: LO=+15 dBm

**Application Circuit**

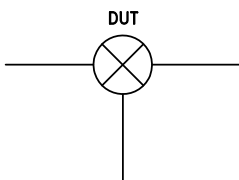

**Product Marking**

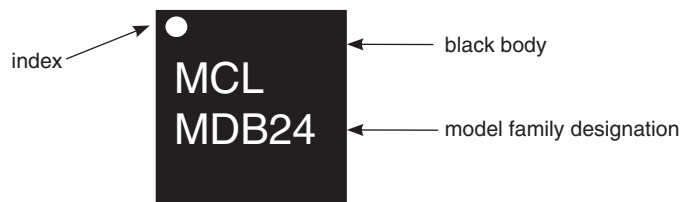

<b>Additional Detailed Technical Information</b>	
<i>additional information is available on our dash board. To access this information <a href="#">click here</a></i>	
<b>Performance Data</b>	Data Table
	Swept Graphs
	S-Parameter (S1P Files) Data Set (.zip file)
<b>Case Style</b>	DG1847 <i>Plastic package, exposed paddle, lead finish: tin/silver/nickel</i>
<b>Tape &amp; Reel</b> Standard quantities available on reel	F68 <i>7" reels with 20, 50, 100, 200, 500 or 1K devices</i>
<b>Suggested Layout for PCB Design</b>	PL-475
<b>Evaluation Board</b>	TB-851-24H+
<b>Environmental Ratings</b>	ENV08T1

### ESD Rating

Human Body Model (HBM): Class 1A (250 to <500V) in accordance with ANSI/ESD STM 5.1 - 2001

### MSL Rating

Moisture Sensitivity: MSL1 in accordance with IPC/JEDEC J-STD-020D

### MSL Test Flow Chart

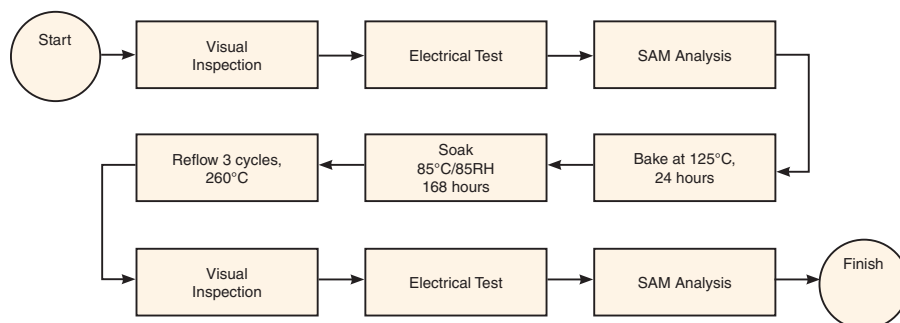

### Additional Notes

- A. Performance and quality attributes and conditions not expressly stated in this specification document are intended to be excluded and do not form a part of this specification document.
- B. Electrical specifications and performance data contained in this specification document are based on Mini-Circuit's applicable established test performance criteria and measurement instructions.
- C. The parts covered by this specification document are subject to Mini-Circuits standard limited warranty and terms and conditions (collectively, "Standard Terms"); Purchasers of this part are entitled to the rights and benefits contained therein. For a full statement of the Standard Terms and the exclusive rights and remedies thereunder, please visit Mini-Circuits' website at [www.minicircuits.com/MCLStore/terms.jsp](http://www.minicircuits.com/MCLStore/terms.jsp)